

Instructions of use for water coolers

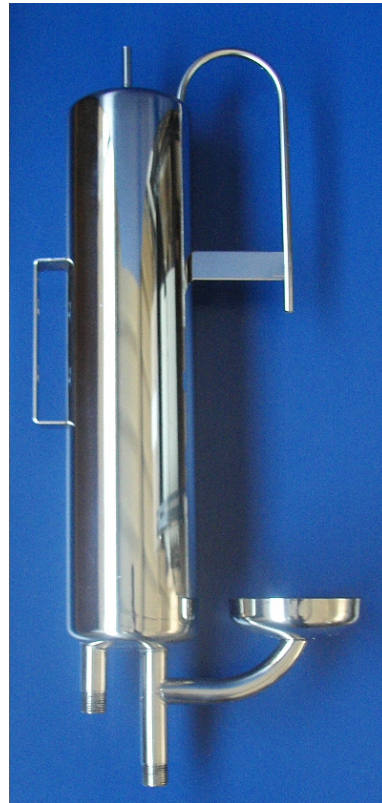

Art.Nr. 880540



Art.Nr. 880538



Art.Nr. 880539



Art.Nr. 880537

Certification 2014/68 UE
Translation from italian original language

Version: 2019 / Fu

Technical changes reserved Gebrüder Heyl Vertriebsgesellschaft für innovative Wasseraufbereitung mbH

Max-Planck-Str. 16, 31135 Hildesheim, Germany
Telefon: +49 (0) 5121 7609 0 / Fax: +49 (0) 5121 7609 44
E-Mail: vertrieb@heylnemeris.de, Internet: www.neomeris.de

Index

1. General instructions/safety	3
1.1 Symbols and clarifications	3
1.2 Other instructions for safety	3
1.3 Destination of use of the cooler	3
1.4 Personnel for coolers	3
1.5 Usage of the cooler: residual risks	4
1.6 Disposal of the cooler	4
1.7 Warranty and product liability	4
2. Working	4
3. Transport and storage	4
4. Limit of use	5
5. Mounting and e connection	5
5.1 Mounting and water connection	6
5.2 Commands	7
6. Condition on the premises	8
6.1 Place of mounting	8
6.2 Water connection	8-9
6.3 Setting example	10
7. Start	11
7.1 Qualifications of personnel	11
7.2 Training of the apparatus	11
8. Maintenance	12
9. Out of service	12
10. Restarting	12-13
11. Certification PED 2014/68 UE	14

1. General instructions for safety

1.1. Symbols and explanations



Danger

**The symbol indicates: a danger for health and life of people.
The wrong respect of indications could damage health and above all dangerous wound for the life.**



Attention

**The symbol indicates: a possible danger for health and life of people.
The wrong respect of indications could damage health and above all dangerous wound for the life.**



Prudence

**The symbol indicates: a possible dangerous situation.
The wrong respect of indications could damage goods (or the plant itself) and it could be create situations which generate possible wounds for people.**

1.2. Others instructions for safety

Respect the current national rules.

1.3. Destination of use of the water cooler

The water cooler is intended to cool the boiler's water to lower the temperature before the analysis.

The analyzer should be used only in regular conditions. Possible breakdowns should be strictly and immediately removed.

Wrong use: do not use the cooler as a boiler to heat the water neither in an open circuit, nor in a closed circuit.
Do not use popper pipes.
Do not close or reduce the flow towards the drain, either that goes towards the drain and that goes towards the withdrawal of water cooled.

1.4 Personnel for the cooler

The cooler should be used only by people in the company who provided first to the reading of the instructions of use, and understood totally their meaning.
Respect always the indications for safety.

1.5. Dangers remained from the use of a cooler.



- to avoid damage caused by the leak of the water, must be fitted a probe (on the floor) giving an alarm signal in case of this event.
- do not touch hot parts of the cooler.
- first to start any work, close the hot and cold water in the boiler.
- maximum allowable pressure 16 bar. Before repair notice that no part is under some pressure and in none of its parts.
- breakdowns caused by leak of the water
- burns
- mechanical energy

1.6. Disposal of the cooler

Dispose the parts of the cooler according to the national rules.

1.7. Warranty and liability of the manufacturer

The product matches at the current level and technical in relation at the date of construction. The cooler is designed and manufactured according to the current technical rules. It sustained a final test and submitted at the quality control.

In response to complaints it values the manufacturer's conditions of sales.

2. Basic operation of the cooler

The water to cool, has been cooled by the cold water's flow.

Used to lower the temperature of the hot water before the analysis.

Models: "manual" model dispatches to the sampling of the hot water for analysis by a testkit, , and an "automatic" dispatches to cool the water before an analyzer does it.

3. Transport and storage

The coolers should be transport only in its container with the closed terminals to avoid that the packaging material enters into.

4. Limit of use

Water should respect the following standard



Parameter	Unit	Max Value
Free Chlorine *	mg/l	0,2
Iron **	mg/l	0,2
Mangle **	mg/l	0,05
Silicate***	mg/l	25
Chlorite****	mg/l	0
PH Value	-	4-8

* Free Chlorine /chlorine bioxide/ozone damages the inner surface of the cooler.

** Iron/mangle: might be melted/unmelted. If unmelted, filter it to keep out the hanging material. If melted, oxidize iron/mangle by a filtration plant or using a specific antiscaling dosage. The scaling on the inner are usually removed with a chemical wash.

*** Silicate, might scale the inner surface.

**** Chlorite might damage the inner surface.

5. Technical data

	Manual	Manual Big	Automatical	Automatical Big
Nr. Ord.	880537	880538	880539	880540
Water's max pressure to cool.	16 bar	16 bar	16 bar	16 bar
Water's max pressure of cooling	8 bar	8 bar	8 bar	8 bar
Hot water's temperature	0 – 80 °C	0 – 120 °C	0 – 80°C	0 – 120°C
Dimension	375 x 150 mm	110 x 150 mm	375 x 128 mm	110 x 128 mm
Weight (empty)	3,3 kg	4,0 kg	1,7 kg	2,3 kg
Hydraulic connection				
Inlet cold water	8 mm	½"	8 mm	½"
Outlet cold water (drain)	½"	½"	8 mm	½"
Inlet water to cool	8 mm	8 mm	8 mm	8 mm
Outlet cooled water	8 mm	8 mm	8 mm	8 mm
Length of the cooling spiral	2,6 metri	5,1 metri	2,6 metri	5,1 metri
Material	Steel titanium AISI316Ti4, EN 1.4571 (mounting holder: AISI316L, EN 1.4404)Titanium steel 1.4571			
Lowering temperature	< 40°C (by the cooling water < 25°C and a water's flow to analyze about 12 ltr/h)			
Classification of the fluid	Class 2 not dangerous fluids			
Classification of the apparatus (according PED 2014/68 UE)	Class A			

5.1. Mounting and hydraulic connection

5.1.1. Automatical coolers

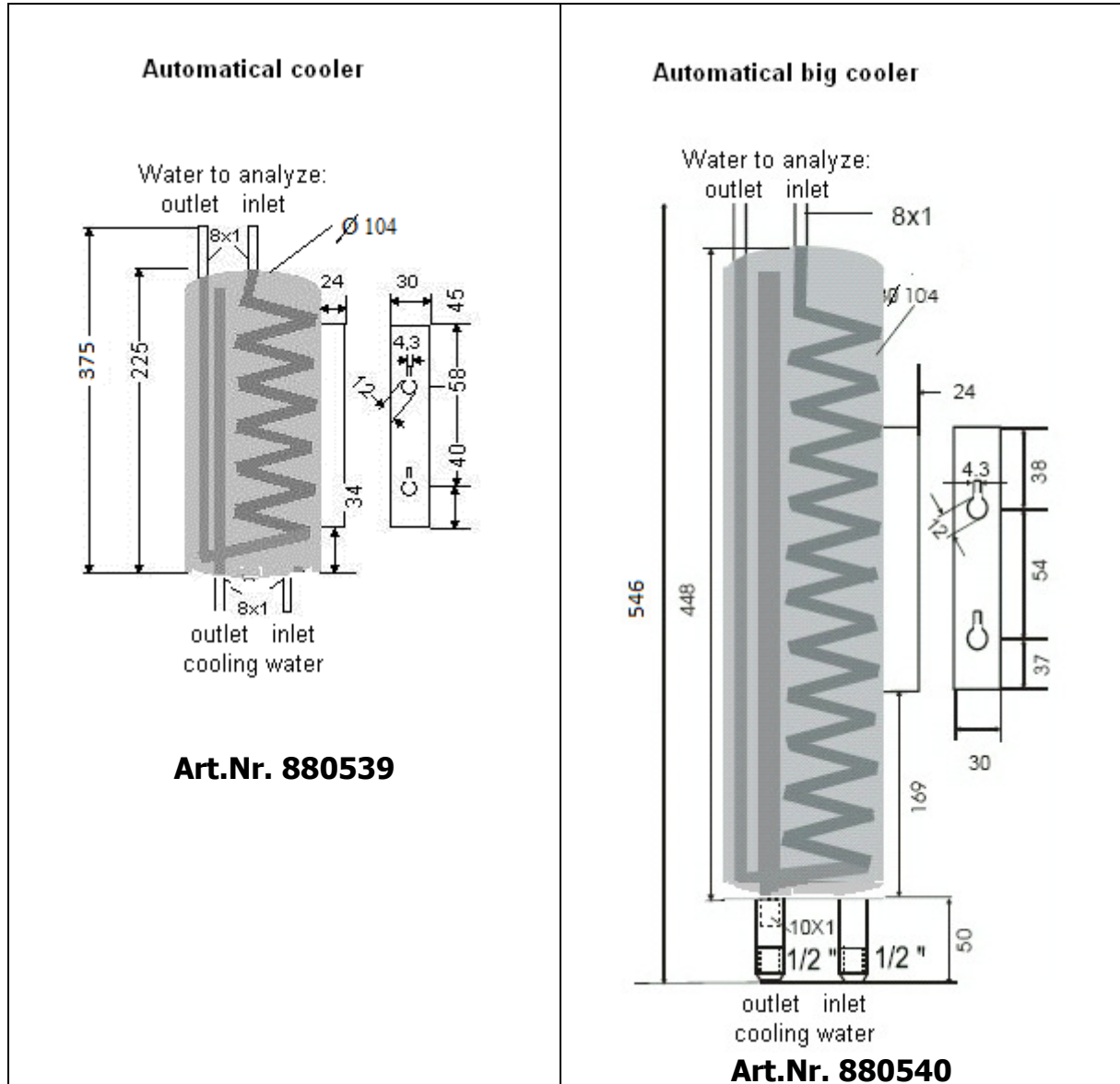

5.1.2. Manual cooler

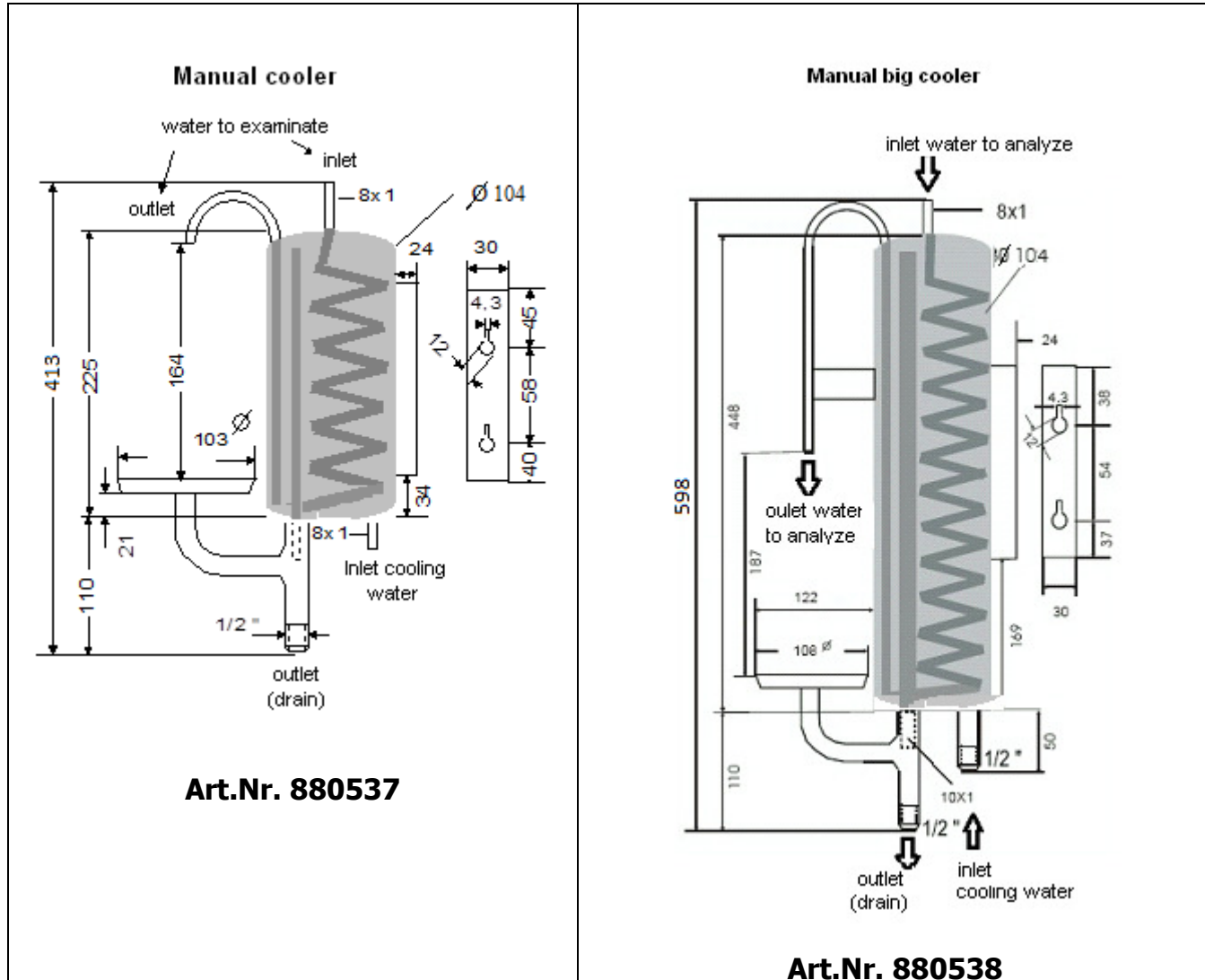

5.2. Commands

Not to consume water during standby of the analyzer you can mount a solenoid valve at the entry of the cold water.



ATTENTION: If you are used a solenoide valve, the analyzer have been provided of a command signal to cool the water before analysis.



ATTENTION: respect the instructions of use of the analyzer, before connecting the analyzer control the time required to reach a temperature < 40°C of the water to examine.. Too hot water might damage the measurement chamber of the analyzer.

6. Contitions on the premises

6.1. Place for mounting

6.1.1. Conditiond on the premises

- mount an overpressure valve on load line of hot water.
- provide a space for mounting (for the size of the cooler see the technical data) greater than 50 cm in every directions (protection for radiation temperature).
- do not expose to the ice
- to avoid breakdowns caused from the leak of the water: an alarm probe "water" on the floor.
- mount respectively a feeding valve for cold and hot water.
- control the drain is free and without pressure.

6.2. Hydraulic connection

6.2.1. Qualification of personnel



Only a qualify person can connect the cooler. Respect the current rules and the company's rules.

6.2.2. water connection

For connection: see the chapter 5.1 and/or 6.3

Cold water incoming

- ☞ Remove the plug incoming cold water
- ☞ Mount a closing valve
- ☞ Connect cold water

Sampling water (hot water to cool)

- ☞ Remove the plug incoming hot water
- ☞ Mount an overpressure valve
- ☞ Mount a closing valve
- ☞ Remove the plug outgoing water to be analyzed
- ☞ Connect to hot water

Drain or cold water output



Danger

- ☞ Remove the plug of the discharge pipe
(Attention: **(with the manual cooler do not forget about the plug into thye support short)**)
- ☞ Connect the drain

Not reduce the flow of cooling water in output (no valves, no lowering, no solenoid valve).

6.3. setting example

Automatical coolers

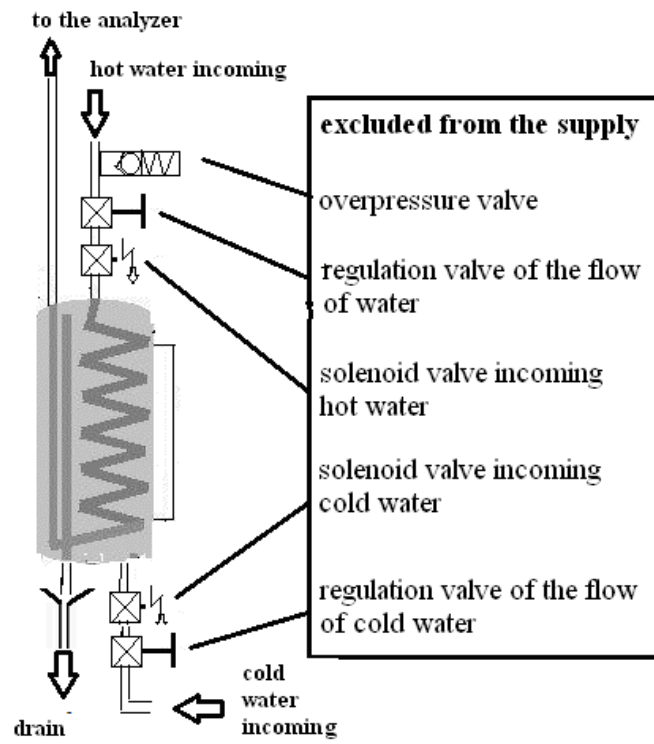

Manual coolers

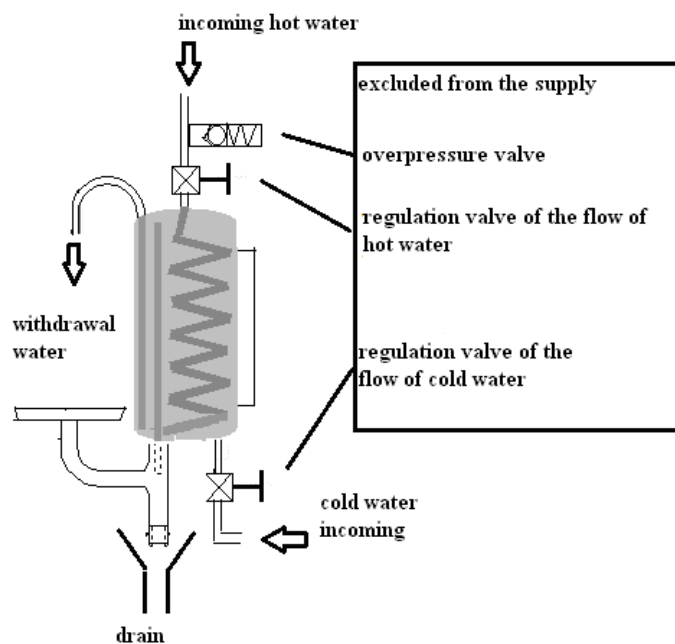

Version: 2019 / Fu

Technical changes reserved Gebrüder Heyl Vertriebsgesellschaft für innovative Wasseraufbereitung mbH

Max-Planck-Str. 16, 31135 Hildesheim, Germany
 Telefon: +49 (0) 5121 7609 0 / Fax: +49 (0) 5121 7609 44
 E-Mail: vertrieb@heyhneomeris.de, Internet: www.neomeris.de

7. Start

7.1. Qualification of the personnel



Prudence

The starting must be executed only by an authorized and certified person.

7.2 Training of the apparatus



Attention

Remove every plug of the transport.

With the manual cooler, do not forget to remove the plug in the shot support.!



Danger

- ☞ unplug the cooler as described in the chapter 6.3
- ☞ Mount an overpressure valve incoming hot water.
- ☞ Mount a regulation valve of the flow incoming cold water and one incoming hot water (the valves are not included in delivery).
- ☞ you can mount electromagnetic valves to the cooler for analyzers either incoming cold water and hot water.
- ☞ and as show the design in the chapter 5.1. Mount a valve to regulate the flow at the entry of the cold water and at the entry of the water to cool (not included in delivery).
- ☞ **at the outlet of the cooling water** any type of valves must not be mounted.
- ☞ open the valve of the cold water (at maximum) and check the hold.
- ☞ open **slowly** the valve of the water to analyze, avoid pressure blows/swings and check their hold. Control the temperature of the outlet water (water to analyze).
- ☞ regulate the valves so that the outlet water (to analyze) has a temperature < 40° C.
- ☞ control the hold.



The cooler is ready to be used, if the water to analyze has a temperature <40°C.
Check the temperature once a week.



Prudence

Do not get over the temperature and the pressure indicates in the technical data.

8. Maintenance



Check visually the cooler at least once a week, this to exclude any leakage of fluid or steam.

It is necessari clean the surface of the cooler with a soft cloth.



Danger

In case of leakage of water or steam:

Close immediately hot water and cooling water. Report the damage (also applying anche applicando a notice (signboard) on the cooler) to avoid any people not aware put the cooler operating again.

Repair the damage only if it is a lackage of water/steam coming from the fittings.

In case of lackage of water or steam coming from a welding, replace the cooler.



Danger

Non eseguire mai saldature sul raffreddatore o sui raccordi.



The overpressure valve has at least an annually obligation to the functional control!



Danger

A oxidized cooler must be replaced.

9. Put out of order



Empty totally the cooler and leave the mounted valves, completely opened. (if possible).

Is not necessary any work of conservation.

10. Restarting

Respect the chapter 5 and 6.



Danger

A cooler or its components oxidized must be replaced.



Danger

The overpressure valve will be tested before restarting!



We advise a test for the cooler with cold water before restarting.